



PROCESS DESCRIPTION



10. 2ND WASHING (VARIO NO. 2)

10.1 Application

The purpose of the 2nd washing (Vario No. 2) is to remove any ash, fines and dirt still in the stock, as well as separating the bulk of the water from the stock which is carried forward to the wetlap machine.

10.2 Operation

De-inked stock from the postflotation system is flow controlled to the suction of the Vario No. 2 feed pump. This pump draws water from Clear Water Chest No. 2 to maintain constant flow to the Vario. The stock is pumped to the headbox of Vario No. 2. The pressure is monitored and adjusted with a hand valve in the pipe. The stock is fed from the headbox into the gap between the moving wire and the rotating center roll. The fines and water pass through the wire and flow to the Vario No. 2 filtrate chest for further processing in the No. 2 Purgomat. The washed and thickened stock is removed from the center roll with the aid of a doctor which is interlocked with the main drive.

The wire is subsequently cleaned with low and high pressure showers. The oscillation of the high pressure shower is interlocked with the main drive and both showers are interlocked via on-off valves.

Stock from Vario No. 2 falls into a chute where showers are located to prevent build-up and to dilute. The chute leads to the Vario No. 2 Stock Chest. This has an agitator to keep the stock from settling.

The stock from the Vario No. 2 Stock Chest is pumped to the Wetlap Supply Chest. The consistency is controlled and the flow is controlled by the level of the Wetlap Supply Chest.



PROCESS DESCRIPTION



The wire is protected against run out by interlocking the wire run out switches with the main drive. The wire tension pressure switch is also interlocked with the main drive.

10.3 Starting Sequence of the Group

This starting sequence includes postflotation, 2nd washing and water clarification No. 2:

- Start water supply pumps and compressor system
- Start water clarification No. 2 group
- Start Vario No. 2
- Start postflotation system

Stock is fed to the system from the bleach tower pump. System can be run with water and stabilized before stock is introduced. During short interruptions, the system runs with water and only the bleach tower pump is stopped.

Automatic Group Start

Precondition: Fill Vario No. 2 Filtrate Chest and Clear Water Chest No. 2 with water.
Fill Purgomat No. 2:

- Purgomat No. 2 bridge drive, paddle drive and screw drive are ready to start
- Purgomat No. 2 pump is ready to start and speed controller set to setpoint
- Purgomat No. 2 aeration booster pump ready to start
- Process air pressure above minimum
- All drive blocks in "auto"
- Vario No. 2 drive ready to start
- All postflotation pumps ready to start
- Bleach tower pump ready to start



PROCESS DESCRIPTION



If all functions are available, group ready signal will be displayed.

Find attached start and stop sequences.

2nd WATER CIRCUIT
GROUP START

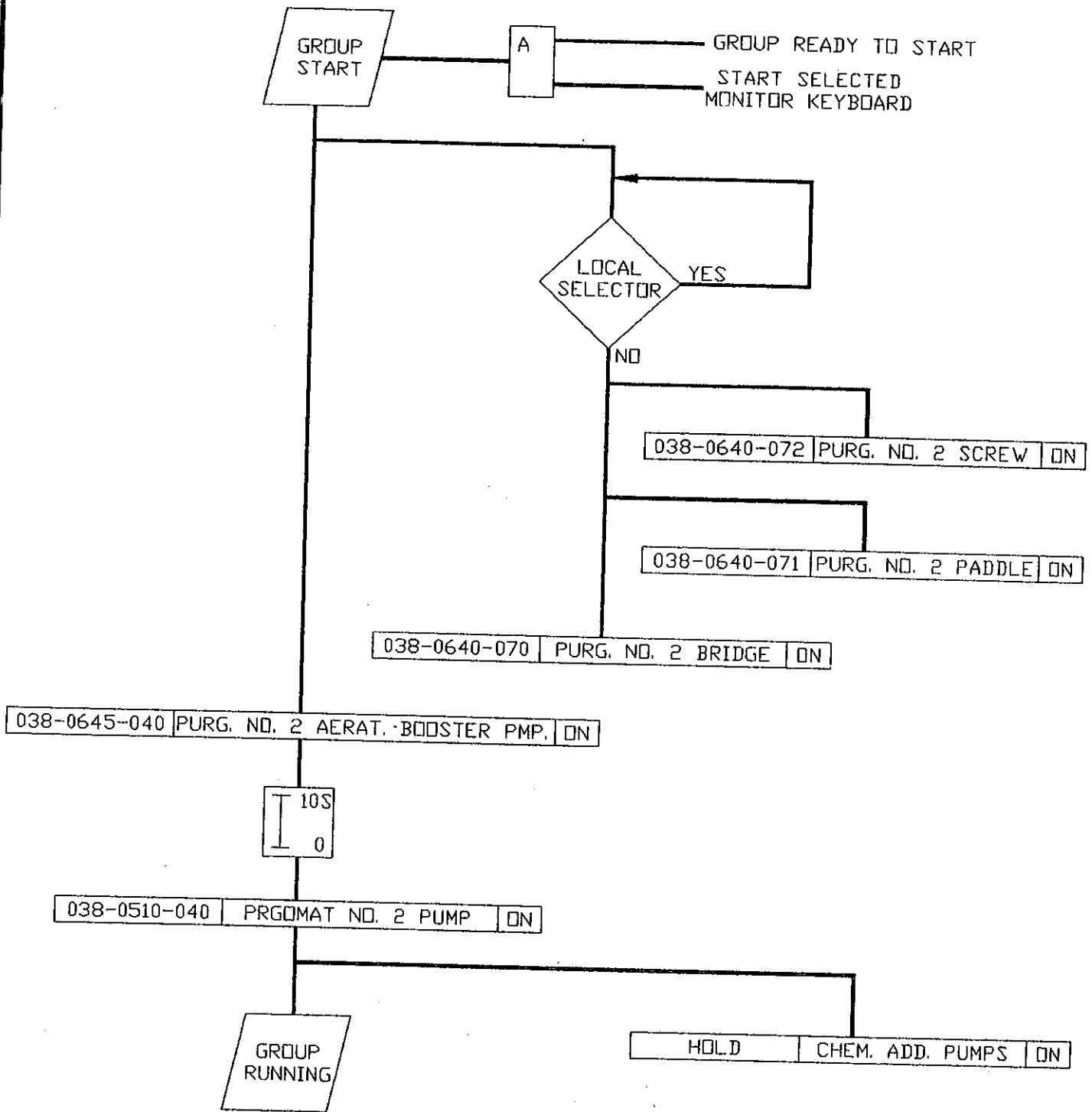

1/29/93	CERTIFIED	AC	0	 BURROWS PAPER CORPORATION LITTLE FALLS, NEW YORK
12/21/92	PRELIMINARY	AC	A	
DATE	REVISION	NAME	REV	
SCALE : NONE	TITLE: 2nd WATER CIRCUIT START/STOP DIAGRAM			CLIENT DWG NO. 500-461
SHEET 1 OF 1				BEW DWG NO. TP11-917-00530
DRAWN BY AC	CHECKED KC	DATE 12/16/92	BIRD ESCHER WYSS INC. MANSFIELD, MA - CAD DRAWING -	

2nd WATER CIRCUIT
GROUP STOP

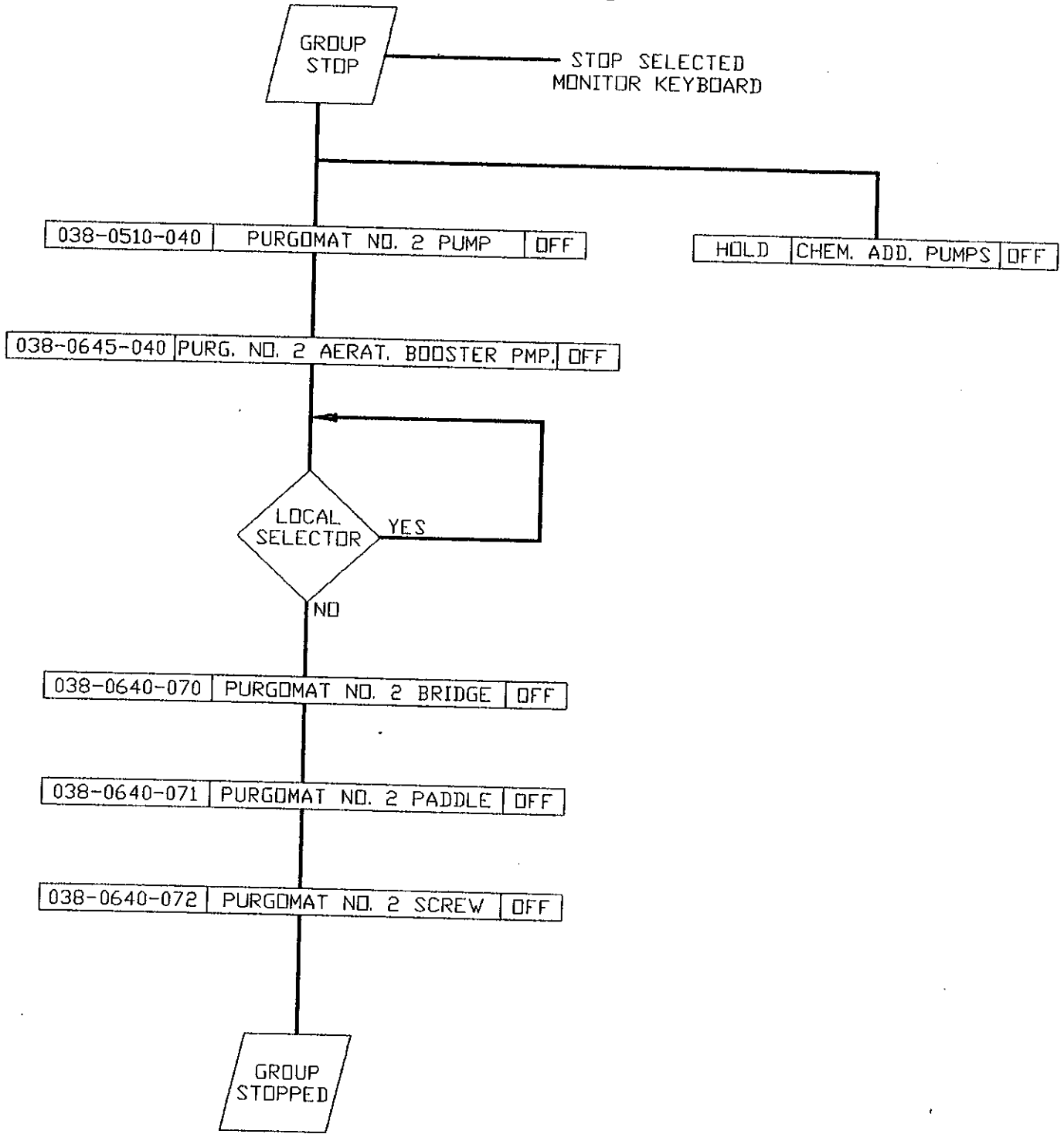

1/29/93	CERTIFIED	AC	0	 BURROWS PAPER CORPORATION LITTLE FALLS, NEW YORK
12/21/92	PRELIMINARY	AC	A	
DATE	REVISION	NAME	REV	
SCALE : NONE				CLIENT DWG NO. 500-460
SHEET 1 OF 1		TITLE: 2nd WATER CIRCUIT START/STOP DIAGRAM		BEW DWG NO. TPI1-917-00520
DRAWN BY AC		CHECKED KC	DATE 12/16/92	BIRD ESCHER WYSS INC. MANSFIELD, MA

- CAD DRAWING -

POST-FLOTATION
GROUP START

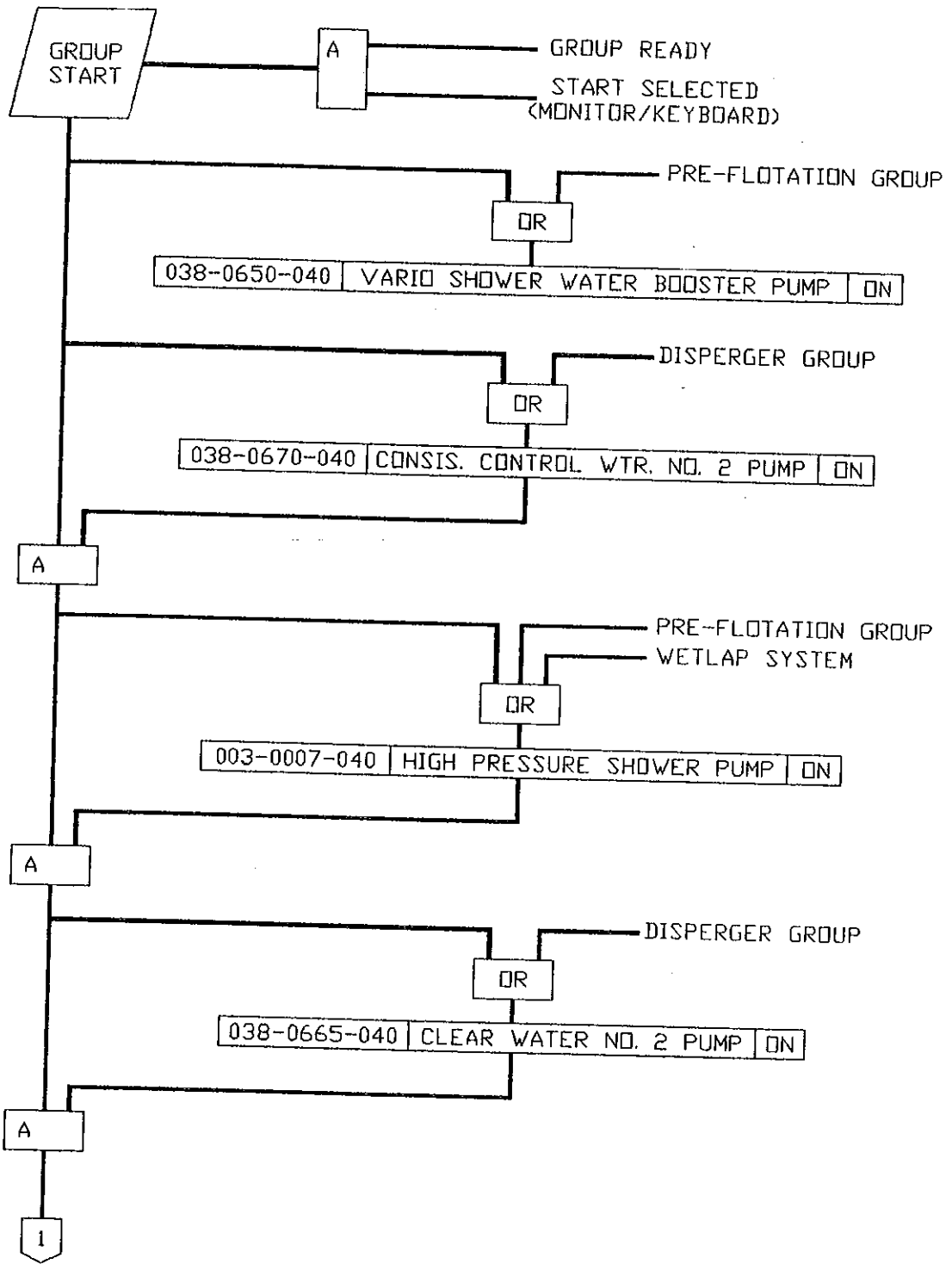

1/29/93	CERTIFIED	AC	0	 BURROWS PAPER CORPORATION LITTLE FALLS, NEW YORK
12/21/92	PRELIMINARY	AC	A	
DATE	REVISION	NAME	REV	
SCALE : NONE				CLIENT DWG NO. 500-456
TITILE: POST-FLOTATION GROUP START/STOP DIAGRAM				BEW DWG NO. TPI1-917-00480
HEET 1 OF 3				BIRD ESCHER WYSS INC. MANSFIELD, MA - CAD DRAWING -
DRAWN BY AC		CHECKED KC	DATE 12/15/92	

POST-FLOTATION
GROUP START

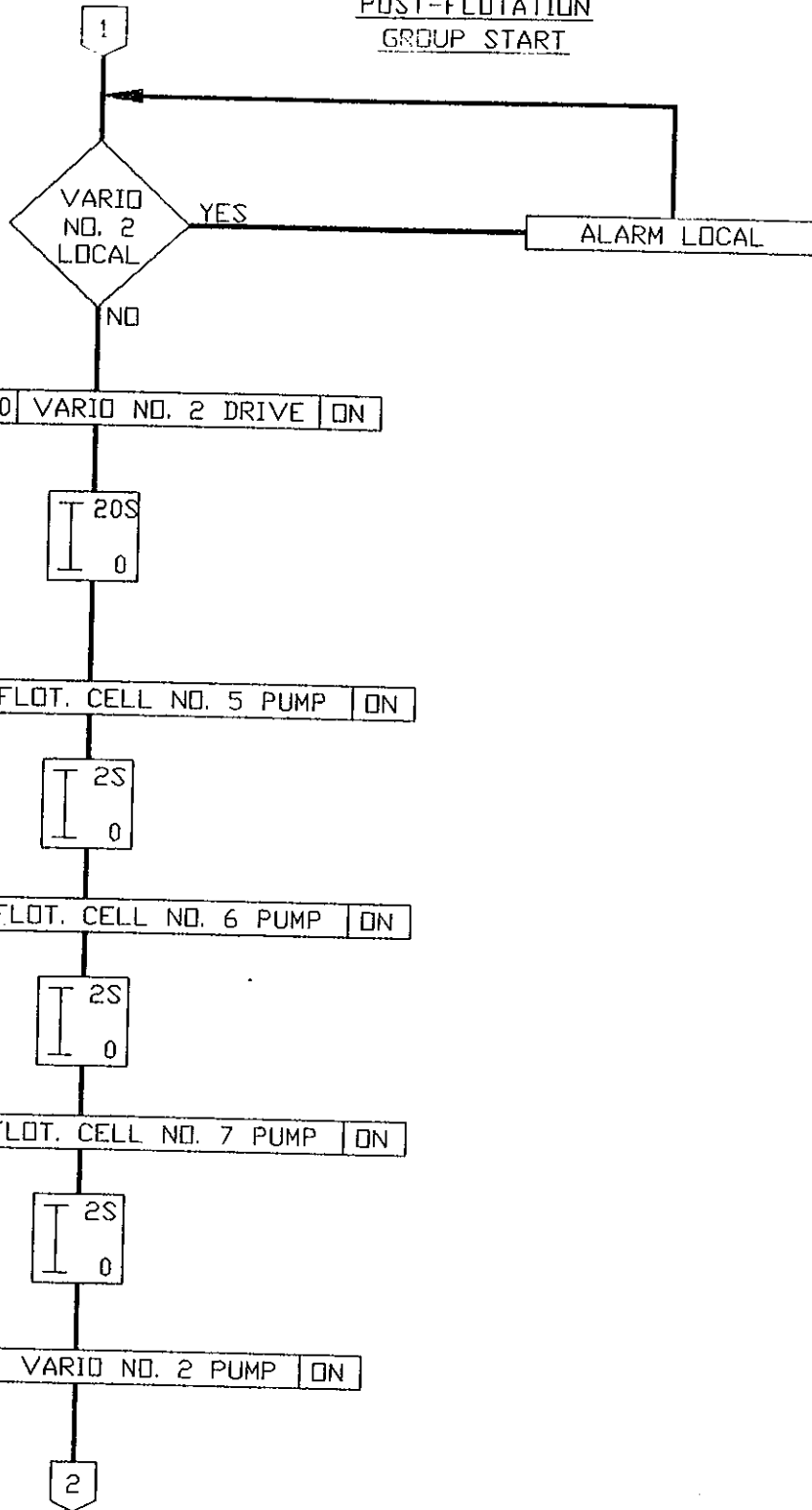

2/16/93	CERTIFIED	AC	1	 BURROWS PAPER CORPORATION LITTLE FALLS, NEW YORK
1/29/93	CERTIFIED	AC	0	
12/21/92	PRELIMINARY	AC	A	
DATE	REVISION	NAME	REV	CLIENT DWG NO. 500-456
SCALE : NONE	TITLE: POST-FLOTATION GROUP START/STOP DIAGRAM			BEW DWG NO. TPI1-917-00480
SHEET 2 OF 3				BIRD ESCHER WYSS INC. MANSFIELD, MA
DRAWN BY AC	CHECKED KC	DATE 12/15/92		

- CAD DRAWING -

POST-FLOTATION
GROUP START

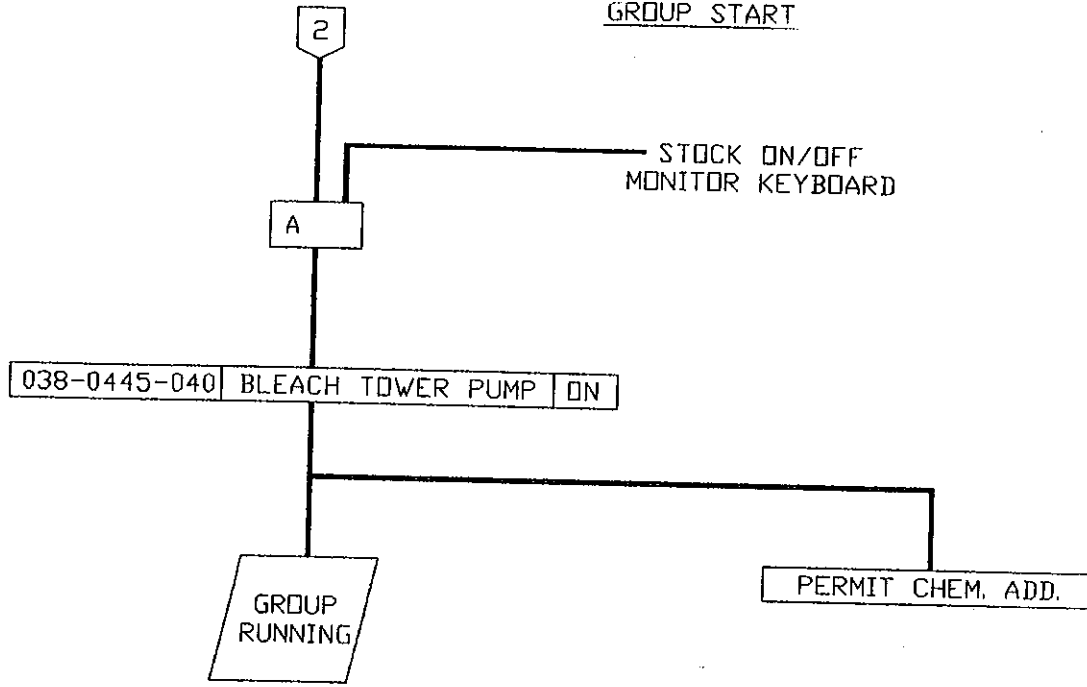

1/29/93	CERTIFIED	AC	0	 BURROWS PAPER CORPORATION LITTLE FALLS, NEW YORK
12/21/92	PRELIMINARY	AC	A	
DATE	REVISION	NAME	REV	CLIENT DWG NO. 500-456
SCALE : NONE	TITLE: POST-FLOTATION GROUP START/STOP DIAGRAM			BEW DWG NO. TPI1-917-00480
SHEET 3 OF 3	DRAWN BY AC CHECKED KC DATE 12/15/92			BIRD ESCHER WYSS INC. MANSFIELD, MA

- CAD DRAWING -

POST-FLOTATION
GROUP STOP

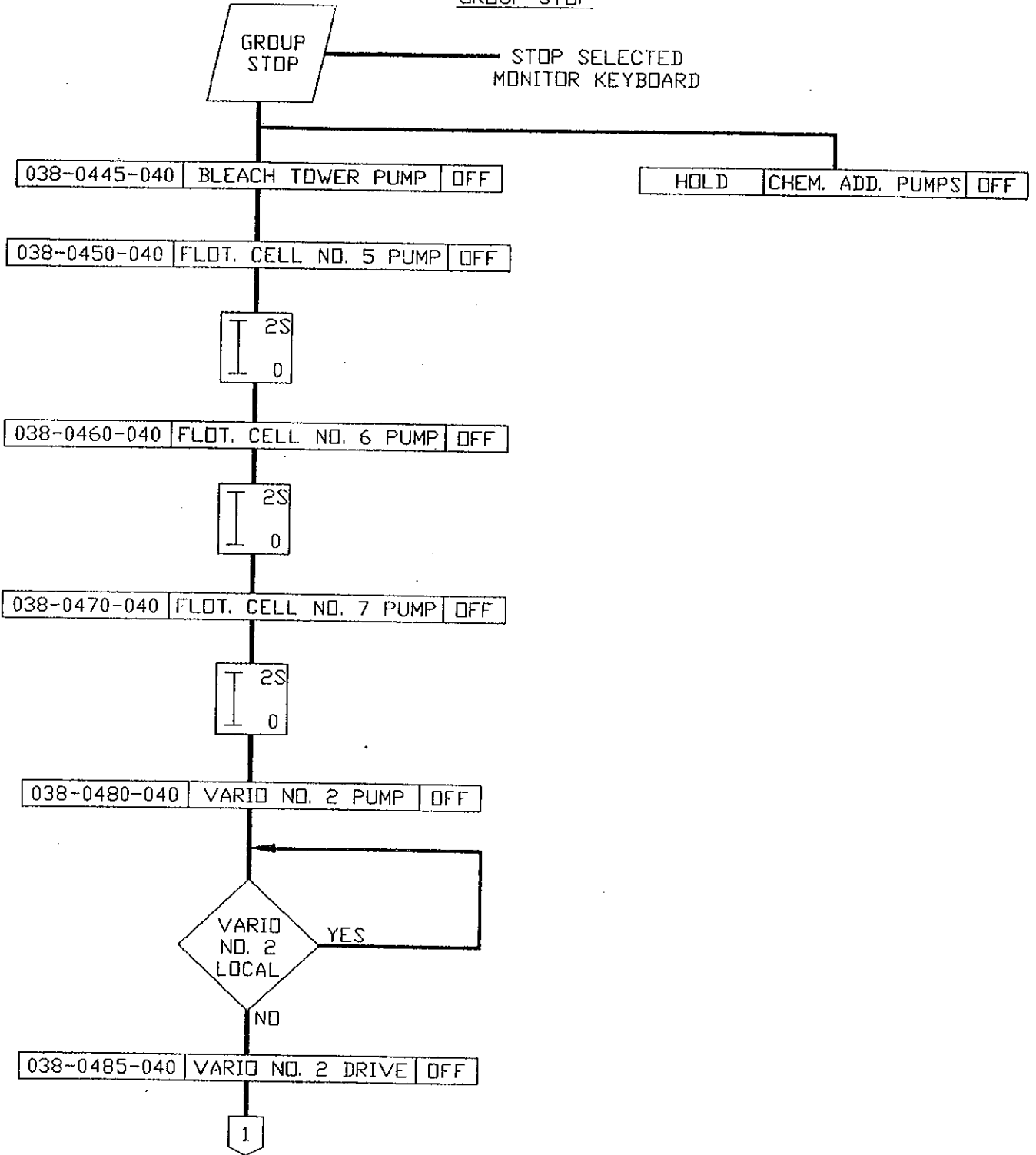

1/29/93	CERTIFIED	AC	0	 BURROWS PAPER CORPORATION LITTLE FALLS, NEW YORK
12/21/92	PRELIMINARY	AC	A	
DATE	REVISION	NAME	REV	CLIENT DWG NO. 500-457
SCALE : NONE	TITLE: POST-FLOTATION GROUP START/STOP DIAGRAM			BEW DWG NO. TPI1-917-00490
SHEET 1 OF 2				BIRD ESCHER WYSS INC. MANSFIELD, MA
DRAWN BY AC	CHECKED KC	DATE 12/15/92		

- CAD DRAWING -

POST-FLOTATION
GROUP STOP

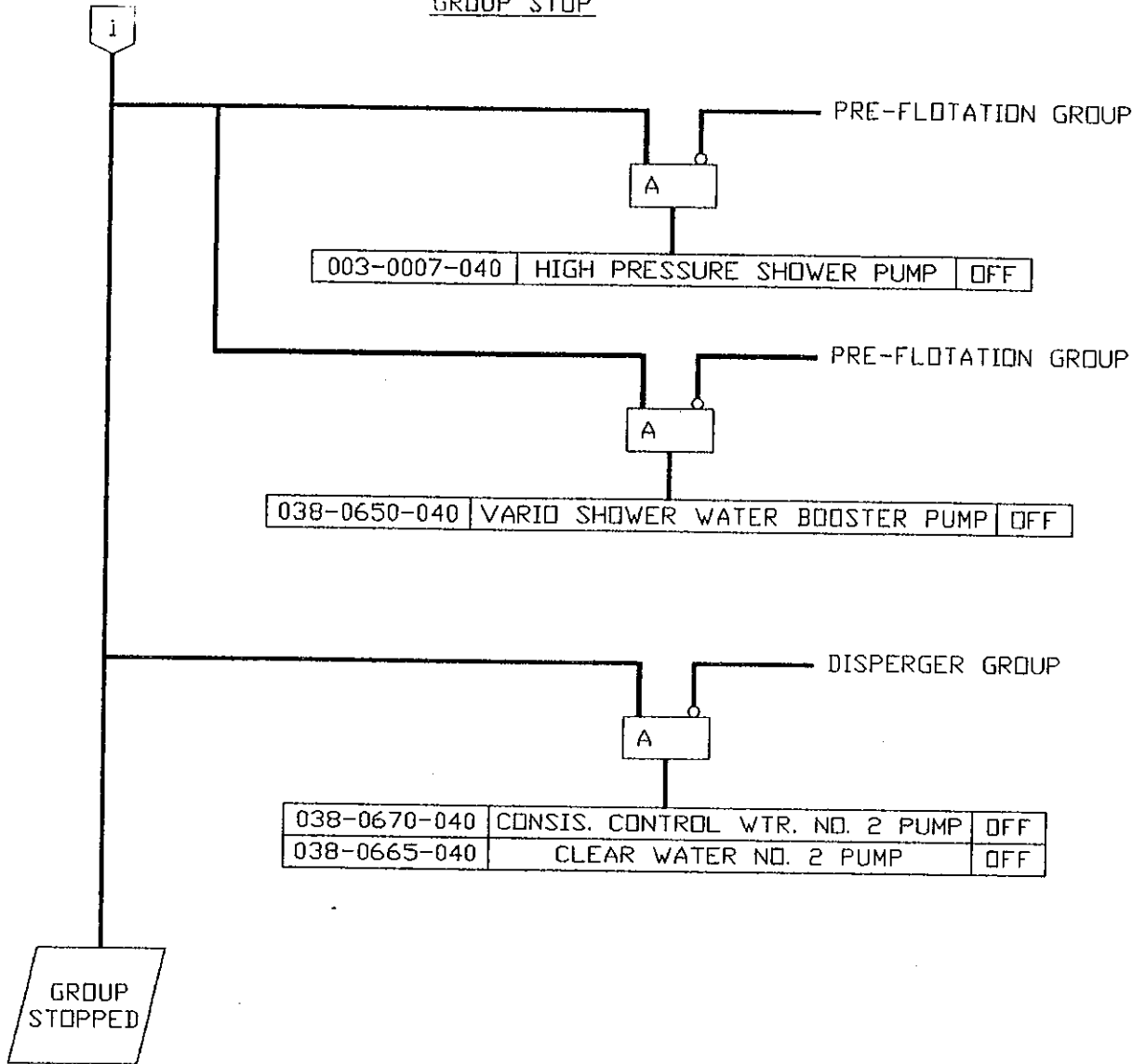

2/16/93	CERTIFIED	AC	1	 BURROWS PAPER CORPORATION LITTLE FALLS, NEW YORK
1/29/93	CERTIFIED	AC	0	
12/21/92	PRELIMINARY	AC	A	
DATE	REVISION	NAME	REV	CLIENT DWG NO. 500-457
SCALE : NONE	TITLE: POST-FLOTATION GROUP START/STOP DIAGRAM			BEW DWG NO. TPI1-917-00490
SHEET 2 OF 2				BIRD ESCHER WYSS INC. MANSFIELD, MA
DRAWN BY AC	CHECKED KC	DATE 12/15/92		

BIRD ESCHER WYSS INC.
MANSFIELD, MA

- CAD DRAWING -

